

# Quick®

**High Quality Nautical Equipment**

## **RRC RADIO CONTROL RECEIVER**

**R02**

**R04**

**R06**

**R08**

**R10**

**R12**



Manual of installation and use

**RRC RADIO CONTROL RECEIVER**



## RRC RADIO CONTROL RECEIVER

The RRC radio control receiver is a device which combined with an RRC radio transmitter is suitable for controlling the operation of devices or accessories installed on recreational crafts.

-  The RRC radio system is a generic radio control whose failed operation must not cause damage to people, animals or property.

The advantages offered by the RRC radio receiver are:

- Full supply range (from 10.5 to 31Vdc).
- Microcontroller-operated functions.
- FSK modulation and carrier frequency 434.420 Mhz.
- Operating temperatures from -15°C to +70°C.
- Indication of the system operating status, errors and problems by means of LED and seven-segment display.
- Protection against polarity inversion.
- Protection against the discharge of the battery.
- 50 transmitters can be stored.
- Translation mode to activate more receivers, installed in different spots, by means of one transmitter.
- Programmable digital filter.
- Two functions can be activated at the same time.
- Possible connection to an external antenna.

## INSTALLATION

**The installation of RRC receiver must be carried out by qualified personnel.**

-  **BEFORE USING THE RADIO RECEIVER, CAREFULLY READ THIS USER MANUAL. IN CASE OF DOUBTS PLEASE CONTACT THE RETAILER OR QUICK® CUSTOMER SERVICE.**

 In case of discordance or errors in translation between the translated version and the original text in the Italian language, reference will be made to the Italian or English text.

 This device was designed and constructed for use on recreational crafts.  
Other forms of use are not permitted without written authorization from the company Quick®.

The RRC radio receiver has been designed and manufactured for the purposes described in this user manual. Quick® is not liable for direct or indirect damages caused by an improper use of the radio control, due to an incorrect installation or errors possibly present in this manual.

-  If the RRC radio receiver is to be installed on boats that are approved or classified according to international laws or national specifications, the installer is responsible to complete requests according to these provisions/classifications.  
Instructions contained in this manual do not guarantee abide and satisfy these provisions/classifications.

**THE PACKAGE CONTAINS:** radio receiver - conditions of warranty - the present manual of installation and use.



## INSTALLATION OF THE RRC RADIOCONTROL RECEIVER

The typical installation procedure will be described here below.

It is not possible to describe a procedure that is applicable to all situations; adapt this procedure to satisfy specific requirements.

The RRC radio receiver must be installed in a dry area, away from motors or electrical generators; these devices, as a matter of fact, generate an irradiated electromagnetic field that can bother the signal received from the receiver.

If the receiver is placed inside a metal structure, then an antenna external to the structure should be installed, as the metal walls block the radio signal.

FIG.1

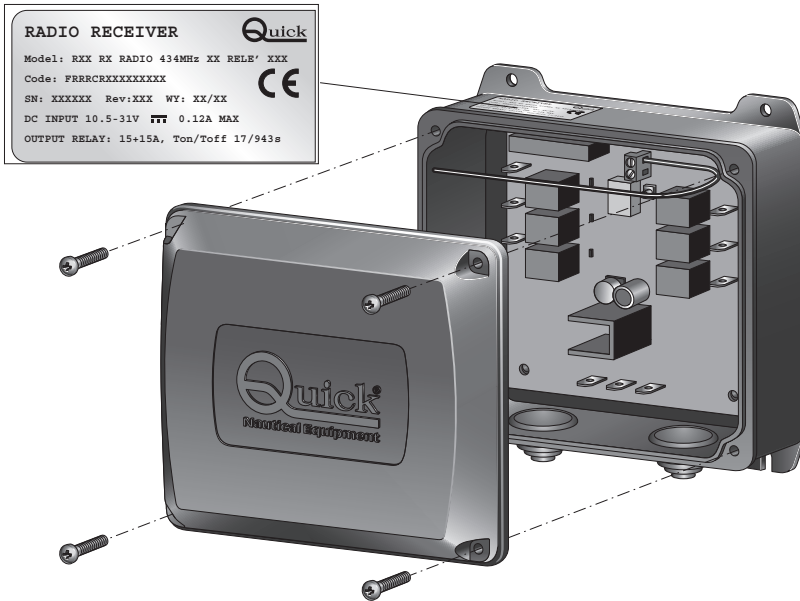

### RADIO RECEIVER

**Quick**

Model: RXX RX RADIO 434MHz XX RELE' XXX

Code: FRRCRXXXXXXXXX

SN: XXXXXX Rev:XXX WY: XX/XX

DC INPUT 10,5-31V  0.12A MAX

OUTPUT RELAY: 15\*15A, Ton/Toff 17/943s



The RRC radio receiver box must be installed vertically (see figure 1), fixed to the support shelf using four screws (not supplied) and positioned at a height of at least 1 metre above the floating level of the boat.

Pay particular attention when drilling holes on panels or parts of the boat.

These holes must not weaken the boat structure or cause it to break.

The RRC radio receiver is compliant with EMC standards (electromagnetic compatibility) but a correct installation is required not to compromise the performances of the device and of surrounding equipment.

For this reason the RRC radio receiver must be installed at a distance of at least:

- 1 m from the compass.
- 1 m from motors.
- 1 m from any radio receiver device.
- 1 m radio transmitting device (with the exclusion of SSB).
- 2 m from any SSB radio transmitting device.
- 2 m from the radar beam.



## INSTALLATION OF THE RRC RADIO RECEIVER

R02 - R04

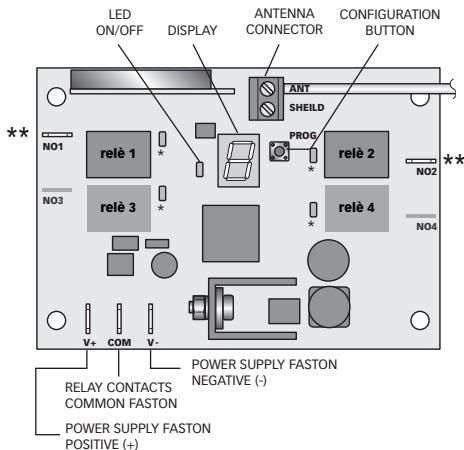

\* RELAY ACTIVATION LED

\*\* OUTPUT FASTON

R06 - R08 - R10 - R12

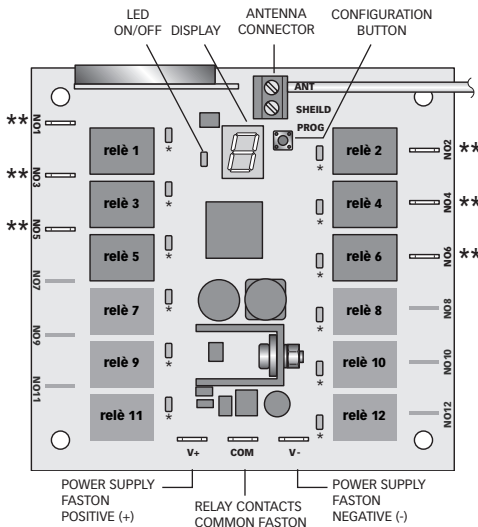

## ELECTRICAL CONNECTION

The RRC radio receiver is compliant with EMC standards (electromagnetic compatibility) but a correct installation is required not to compromise the performances of the device and of surrounding equipment. For this reason the RRC receiver's wire must be placed at a distance of at least:

- 1 m from cables that carry a radio signal (with the exclusion of SSB radio transmitters).
- 2 m from cables that carry a radio signal for SSB radio transmitters.
- 1 m from NMEA cables or electrical power lines.

Follow the rules listed here below to implement the electrical system for the RRC radio receiver (see fig. 2).

**WARNING:** before connecting or disconnecting cables from the electrical terminals of the receiver, make sure that it is not powered.

- Power the RRC radio receiver only after verifying that all electrical connections have been carried out properly and the correct power supply voltage value described on the rating label (fig.1) positioned on top of the box of the radio receiver.
- Use faston terminals (not supplied) to connect the cables to the receiver.
- Insert a switch (not supplied) to turn on and off the RRC radio receiver and interrupt the common wire of the relay contacts. The distance between the switch's contacts must be at least 3mm.
- Position the switch so that it can be easily reached if it is necessary to shut-off the device to prevent dangerous situations.
- Correctly decide the size of the wires section, according to their length, for power supply wires, common wires and those connecting to the devices being used.
- The RRC radio receiver must be powered by the battery using a separate line. Insert a 1A quick fuse (not supplied) on the power supply line.
- On the "COMMON" input line, insert a fuse (not supplied) of the correct size, according to the absorption of the used devices.



## CONNECTION EXAMPLES

R02 - R04

FIG.2

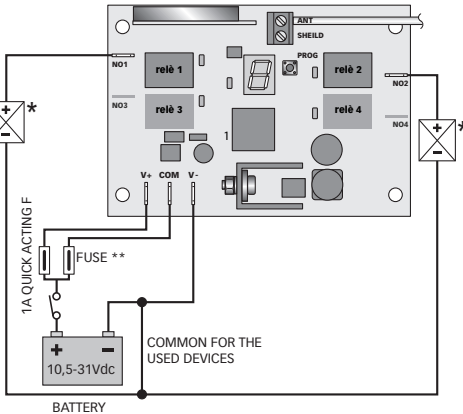

\* DEVICES USED IN DIRECT CURRENT

\*\* THE FUSE VALUE MUST BE CHOSEN BASED ON ABSORPTION OF THE USED DEVICES.

R06 - R08 - R10 - R12

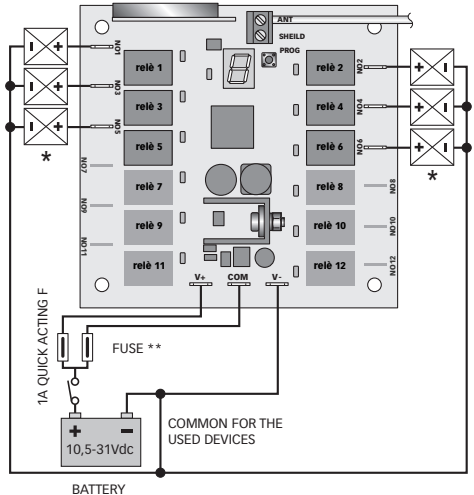

## EXTERNAL ANTENNA

If the installation of an external antenna is required, proceed as follows:

- remove the internal antenna, made of an 8 cm long folded wire, from the ANT input (fig.3).
- Connect the centre core of the coaxial cable of the antenna to the ANT input (fig.4). The metallic shield must be connected to the SHIELD input.
- Coaxial cable during laying must not be throttled and bended at a right angle. Must also be taken away from heat sources.
- The antenna must be installed vertically at a distance of at least 1 metre above the boat floating level, away from electrical sources of disturbance and not inside any metal structures.
- Do not install the antenna close to that of other equipment as VHF, radar, GPS, etc.

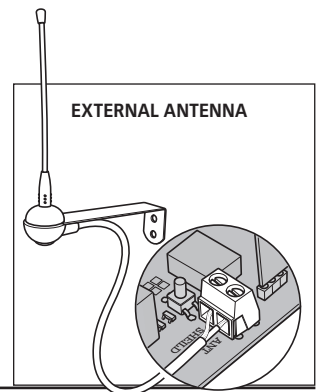
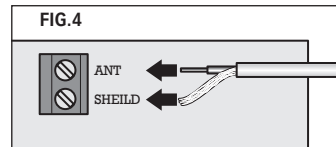
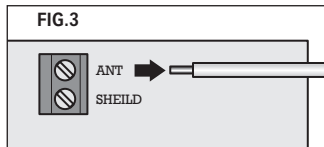

## OPERATION

### Start-up

The receiver starts-up once the power supply is connected. After start-up, the ON/OFF LED and all display segments will light up for a short time.

### Awaiting signal status

The ON/OFF LED flashes slowly. The receiver waits for a valid command from a stored transmitter or for configuration.



## RECEIVER CONFIGURATION

 **WARNING:** during the entire configuration phase, the receiver's relays are not active.





 **WARNING:** during the entire configuration phase of the receiver, the ON/OFF LED will remain off.

Press the configuration button to enter the receiver's configuration menu. The dot on the display lights up to show that it has been pressed.

Press the configuration button and keep it pressed; the external segments of the display will light up in rapid clockwise succession and will then show the letter  of the first menu item steadily on. Release the configuration button.

By quickly pressing and releasing the configuration button the next item in the menu can be selected (see configuration menu table).

### Configuration menu table

DISPLAY	DESCRIPTION
	Programming without translation
	Programming with translation
	Filter function
	Deleting receiver memory
	Exiting the configuration menu

In order to confirm the choice of the menu item, keep the configuration button pressed until the chosen letter flashes regularly.

### Programming function (letter )

This function allows to store the transmitter ID in the receiver's memory.

The relays will be programmed in sequence, button 1 of the transmitter will correspond to relay 1, button 2 will correspond to relay 2, and so on.

Once letter  has been selected (always on) keep the configuration button pressed until the letter flashes constantly. Release the configuration button.



Press any key on the transmitter, the letter  will start flashing quickly to confirm that transmitter ID has been stored in the receiver's memory.

If the transmitter key is pressed for more than 5 seconds, the receiver will exit programming status and go back to a fixed .

In sequence other transmitters can be programmed, up to a maximum of 50. Once 10 seconds have passed after entering the programming function or receiving the last valid ID, the receiver will exit programming status and go back to letter  constantly on. It is also possible to exit this function by pressing and releasing the button.

### Programming function with translation (letter )

Besides storing transmitter ID into the receiver's memory, this function allows to translate the sequence of active relays based on the button pressed. This function allows to use a single transmitter to control multiple receivers placed in different spots.

Once letter  has been selected (always on) keep the configuration button pressed until the letter  flashes constantly. Release the configuration button.

Press the key on the transmitter that has to be matched with relay 1. The letter  will flash quickly and confirm that the transmitter ID has been entered in the receiver's memory.

If the transmitter key is pressed for more than 5 seconds, the receiver will exit configuration status and go back to a fixed .

In sequence other transmitters can be programmed, up to a maximum of 50. Once 10 seconds have passed after entering the programming function or receiving the last valid ID, the receiver will exit programming status and go back to letter  constantly on. It is also possible to exit this function by pressing and releasing the button.



Example of programming with translation:

**Press key 3 on an RRC radio transmitter.**

KEY PRESSED ON THE TRANSMITTER	CORRESPONDENCE TO ENABLED RELAY ON THE RECEIVER
1	(None)
2	(None)
3	1
4	2

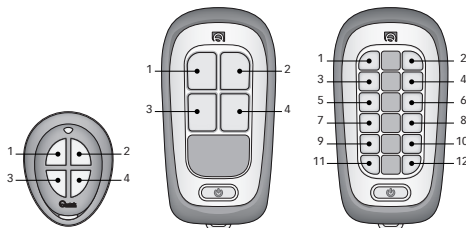

Key 3 corresponds to relay 1, key 4 corresponds to relay 2.

### Filter function (letter $\text{F}$ )

This function allows to select three different interference noise filtering modes within the function submenu (see table).

The receiver is supplied set in AVERAGE mode.

### Filter function submenu table

$\text{L}$	LOW: select when using in environments with only slight interference
$\text{F}$	AVERAGE: factory setting. Select when using in normal conditions
$\text{H}$	HIGH: select when using in environments with great interference

Once selected, letter  $\text{F}$  remains on; keep the configuration button pressed until letter  $\text{H}$ ,  $\text{F}$  or  $\text{L}$  (depending on the current setting saved in the receiver) flash at a constant frequency.

Release the configuration button. By subsequently quickly pressing and releasing the configuration button letter  $\text{H}$ ,  $\text{L}$  or  $\text{F}$  (flashing at a constant frequency) can be selected. Once the configuration has been chosen among those selectable, keep the configuration button pressed until the letter starts to flash at a fast rate, confirming that it has been saved; next, the letter  $\text{F}$  will appear and remain on. Release the programming button

After 10 seconds, if the configuration button is not pressed, it will go back to the letter  $\text{F}$  being on constantly.

### Erasing the memory (letter $\text{E}$ )

This function allows to erase from the receiver's memory all transmitter IDs that have been saved using the  $\text{H}$  or  $\text{F}$  programming function.

Once letter  $\text{E}$  constantly on is selected, keep the configuration button pressed until letter  $\text{E}$  stored flashing regularly, passed 3 more seconds, it will start flashing at a faster rate. This confirms that it has been erased and then the letter remains on. Release the programming button.

If the programming button is released before 5 seconds have passed, letter  $\text{E}$  will go back to being on constantly and the erasing procedure is cancelled.

### Exiting the configuration menu ( $\text{E}$ symbol)

This function allows to exit from the configuration menu of the receiver.

Once the  $\text{E}$  symbol is selected, keep the configuration button pressed, the  $\text{E}$  symbol will start flashing quickly before shutting off. Release the configuration button. When exiting the configuration phase the ON/OFF LED will start flashing again.

## RADIO RECEIVER OPERATION

### Reception of a command from the transmitter

When receiving a command from the RRC radio transmitter, the green ON/OFF LED will start flashing quickly. The corresponding relay will activate and its activation is displayed by the red "relay activation" lighting up. Two relays can be activated at the same time.



## SYSTEM ERRORS

During the start-up phase the radio receiver can display the presence of system errors.

### Flash checksum error

If this error is detected on start-up, the ON/OFF LED flashes quickly.

In this case it is necessary to contact the after-sales assistance centre or Quick® customer service.

## PROBLEMS WITH AUTOMATIC RESET

The reset for this class of problems takes place automatically, as soon as the cause of the problem disappears.

---



**0** Low power supply voltage. Power supply voltage is less than 9.5 Vdc. When this signal is active, the relays are deactive. The signal ends when power supply voltage is once again above 9.5 Vdc

---

## SIGNALS

---

**0** Receiver's memory is full. The maximum number of transmitters has been reached (50). In order to add more transmitters it is necessary to complete the memory erasing function (all previously stored transmitter IDs will be erased).

Signal is only active during the  or  programming phase.

---

**1** Transmitter code is already in memory. The signal for this problem is only active during the  or  programming phase.

---

**2** Transmitter ID is not valid. The transmitter cannot be coupled to the receiver in use.

---

**3** Transmitter ID is not in memory. This signal is displayed when a correct transmitter ID is received but it is not present in receiver's memory.  
This signal may appear when there is another RRC Quick® system operational in the surrounding area

---

**4** The radio data packet received contains errors. The receiver has detected an error in the data packet received due to the presence of interference. If this signal appears frequently, verify that the receiver has been installed correctly.

---

**6** RSSI level insufficient. The level of the radio signal received is below the threshold value of the selected filter. Verify that the internal or external (if present) antenna has been installed correctly.

---

**8** Translation function is not possible. The programming with translation function is not possible for the transmitter type in use.  
Display is only active during the  programming function.

---





## MAINTENANCE

The RRC radio receiver does not require particular maintenance. In order to ensure optimal operation of the remote control, once a year verify cables and electrical connections.

## TECHNICAL DATA

MODELS	R02	R04	R06	R08	R10	R12
<b>INPUT CHARACTERISTICS</b>						
Power supply	10,5 ÷ 31 Vdc					
Quiescent current	25 mA					
Absorption with 2 relays activated	120 mA					
<b>OUTPUT CHARACTERISTICS</b>						
Relay number	2	4	6	8	10	12
Relay contact rating*	15A					
<b>CHARACTERISTICS OF THE RECEIVER</b>						
Frequency	434.420 Mhz					
Modulation	FSK					
Number of transmitters that can be stored	50					
Compliant with directive	2014/53/EU (RED)					
<b>GENERAL CHARACTERISTICS</b>						
Operating temperature	from -15°C to +70°C					
Dimensions (W x H x D)	143 x 141,7 x 61,4 mm					
Weight (with all relays installed)	300 g		370 g			

\* With two enabled relay, having a load of 15A each (30A total), the nominal operating time is 17 seconds and the idle time is 16 minutes.  
With one enabled relay, having a load of 15A, the nominal operating time is 10 minutes and the idle time is 10 minutes.

## RRC DIMENSIONI (mm)

DIMENSIONS - DIMENSIONS - ABMESSUNGEN - DIMENSIONES



- R02 • R04
- R06 • R08
- R10 • R12

